



Engine Driven Solids Handling Pumps

- *Heavy Duty Cast Iron Construction*
- *Buna or Viton® Mechanical Seal*
- See Spec Chart for Specific Model
- *1-1/2" to 3" NPT Port Sizes*
- *Self-Priming up to 20 ft.*
- *Semi-Open, Clog Resistant Impellers*
- *Engine Options: B&S, Honda or Yanmar*
- *Available in 3-1/2 to 9 HP Engines*
- *Solids Handling up to 3/4" Diameter*
- *Electric Start Option on 9 HP Models*
- *Pumps Include Heavy Duty Steel Roll Frames*
- *Wheel Kits Available with Semi-Pneumatic or Pneumatic Tires*



2" Solids Handling Pump with Wheel Kit A734-90

The AMT line of Engine Driven Solids Handling pumps offers an upgraded debris handling capability in wear resistant Cast Iron construction. Applications include high volume liquid transfer, irrigation, commercial draining and construction. All these models feature removable/replaceable Cast Iron wearplate/volute, clog resistant impellers and/or wearplates to ensure a long life for the complete pump. Dual volute design reduces radial load on engines.

AMT Engine Driven Solids Handling pumps are reliable, cost effective and low maintenance. Many are readily available "Off-the-Shelf" for fast 24 hour shipment. For use with non-flammable liquids which are compatible with pump component materials.

Viton® is a registered trademark of E.I. DuPont

INDUSTRIAL DUTY



3" Solids Handling Pump

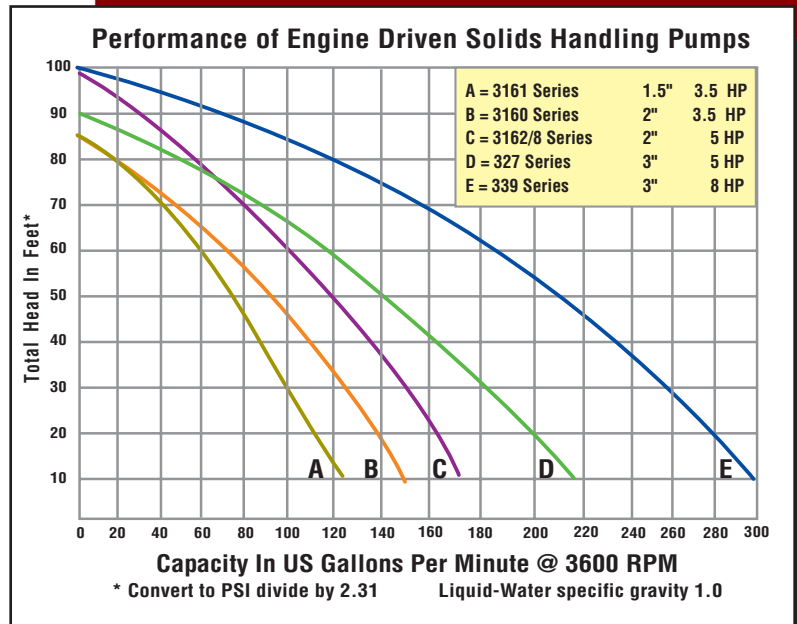

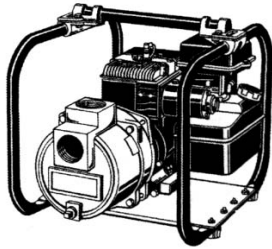

1.5" & 2" Cast Iron Solids Handling Pumps

Model#	Curve	Ports	Driver	Seal	Ship Wt.	Run Time	Tank size
3161-95	A	1.5" NPT	3.5HP B&S	Buna	75	180 min.	3 qt.
3160-95	B	2" NPT	3.5HP B&S	Buna	75	180 min.	3 qt.
3162-95	C	2" NPT	5.5HP B&S Intek OHV	Buna	82	90 min.	3 qt.
3168-95	C	2" NPT	5HP Honda OHC	Buna	80	60 min.	1.8 qt.

Maximum Solids Handling Capability: 3/8" Diameter

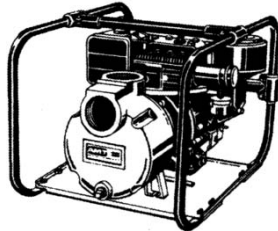

3" Cast Iron Solids Handling Pumps

Model#	Curve	Ports	Driver	Seal	Ship Wt.	Run Time	Tank size
3270-95	D	3" NPT	5.5HP B&S Intek OHV	Buna	109	90 min.	3 qt.
327A-V5	D	3" NPT	5HP Honda OHC	Viton®	107	60 min.	1.8 qt.
3270-D5	D	3" NPT	4.7HP Yanmar Diesel	Viton®	126	110 min.	2.6 qt.
3390-95	E	3" NPT	8HP B&S Intek OHV	Buna	137	90 min.	4 qt.
3393-V5	E	3" NPT	9HP Honda OHV	Viton®	138	100 min.	6.4 qt.
3391-V5	E	3" NPT	9HP Honda OHV++	Viton®	170	100 min.	6.4 qt.

Maximum Solids Handling Capability: 3/4" Diameter
 ++ 12V DC Electric Start (battery not included)

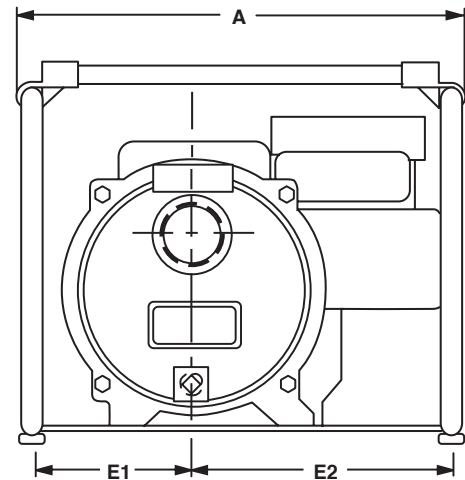

Optional Wheel Kits

for roll frame pumps (3.5 thru 9 HP)

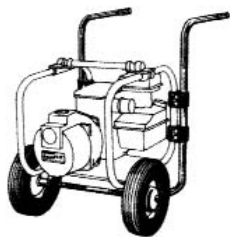

Model #	Features	Ship Wt.
A734-90	Includes 10" semi-pneumatic tires on steel wheels with cast iron clamps and steel handle for universal mounting to frame.	26 lbs.
A735-90	Includes 16" pneumatic tires on steel wheels with cast iron clamps and steel handle for universal mounting to frame	29 lbs.

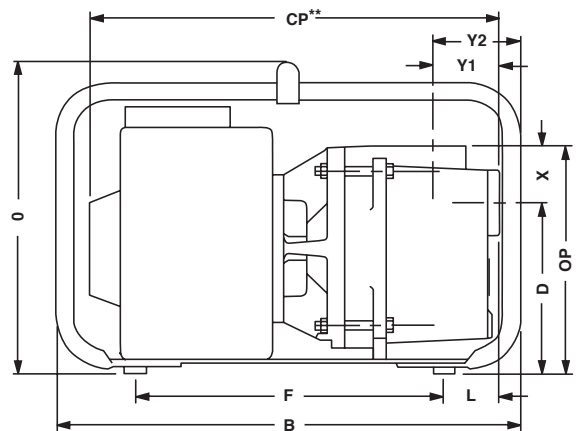

MODEL#	HP	A	B	CP**	D	E1	E2	F	L	O	OP	X	Y1	Y2
316 Series	3HP	15.5	19.0	17.5	6.8	5.0	9.0	8.5	4.5	16.0	9.5	2.6	3.1	4.6
316 Series	5HP	19.5	24.3	19.0	6.8	5.0	10.0	8.5	6.0	20	9.5	2.6	3.1	4.6
327 Series	5HP	19.5	24.3	19.0	10.3	5.0	10.0	8.5	6.0	20	13.8	3.5	4.8	6.0
339 Series	8HP	21.3	27.3	23.5	10.3	7.0	11.0	15.0	6.0	23.0	13.8	3.5	4.8	6.0

(**) This dimension may vary due to engine manufacturer's specifications
 NOTE: Dimensions have a tolerance of ±1/8".

Viton® is a registered trademark of E.I. DuPont

See price book page 3

The Gorman-Rupp Company reserves the right to discontinue any model or change specifications at any time without incurring any obligation.

Standard Features

- > Two NPT Pipe Nipples
- > Viton® or Buna Mechanical Seals
- See spec chart for specific model
- > Self-priming to 20 ft.
- > Semi-Open, Clog Resistant Cast Iron Impeller
- > Stainless Steel Shaft Sleeve
- > Maximum Temperature 180° F
- > Maximum Working Pressure 60 PSI
- > Wear Resistant Cast Iron Replaceable Volute/Wearplate and Impeller
- > Solids Handling Capability