

AFL 0600 to 1200

ABS Submersible Mixed Flow Pumps for Large Volumes at Low to Medium Heads

- for wastewater and sewage containing solid or fibrous matter and for sludges
- for use in combined rain water and sewage pumping stations, dewatering installations, reclaimed land dewatering and for use in municipal and industrial areas
- easy installation in the riser pipe by means of a self centering, self sealing coupling system
- easy maintenance thanks to the compact modular unit design
- automatic moisture detection and temperature monitoring
- newly developed hydraulics with broad band of high efficiencies
- available in standard and explosion proof versions



AFL 0600 to 1200

Application areas

AFL Submersible pumps can be used everywhere where large volumes of process water or wastewater containing solid effluent must be pumped. Even liquids with fibrous components are no problem for this pump series.

The AFL pumps can be applied as any of the following:

- sewage pumps
- active sludge pumps
- combined sewage and surface water pumps
- drainage pumps in pumping stations for dewatering reclaimed land in low lying coastal areas
- storm water pumps for storm protection in areas liable to flooding
- transfer pumps to control the water level in lakes and lagoons subject to tidal influence
- industrial raw water and process water pumps, pumps for dry docks, canals and harbours
- cooling pumps in power plants
- raw water pumps for preparation and supply of drinking water
- irrigation pumps to allow areas of low rainfall to be used for agricultural and other purposes

Design

An economical modular system provides for optimum combination of hydraulics and motor to suit the required operating conditions. Compact adaptable construction system.

Motor

In water tight housing, protected to IP 68 and insulation class F with lubricated for life maintenance free bearings and high quality silicon carbide mechanical seal.

Robust shaft construction for many years of operation under constant heavy load. Overdimensioned bearings with grease lubrication are maintenance free.

Your guarantee for a long reliable operating life.

Can be supplied in explosion proof form with European Certification or US FM Certification.

Hydraulics

Mixed flow impellers with large free passage ensure blockage-free operation at high efficiencies. Large performance field for practically all applications and excellent efficiencies.

Installation

Suitable for installation in steel or concrete riser pipes for economical operation and simple installation.

The centering of the pump and sealing between pump and pipe line is achieved automatically by means of a conical coupling ring.

No additional installation work required.

Maintenance

Easy maintenance and flexibility are the characteristics of the AFL pumps.

Continuous stator, bearing and seal monitoring systems provide effective remote surveillance of these major components. All bearings are lubricated for life and maintenance free. An oil change is only necessary if the moisture sensor in the oil chamber has activated.

Flexibility instead of rigid inspection intervals.



**The
advantage:
Reliable and
economical
running**

AFL 0600 to 1200

Performance Range

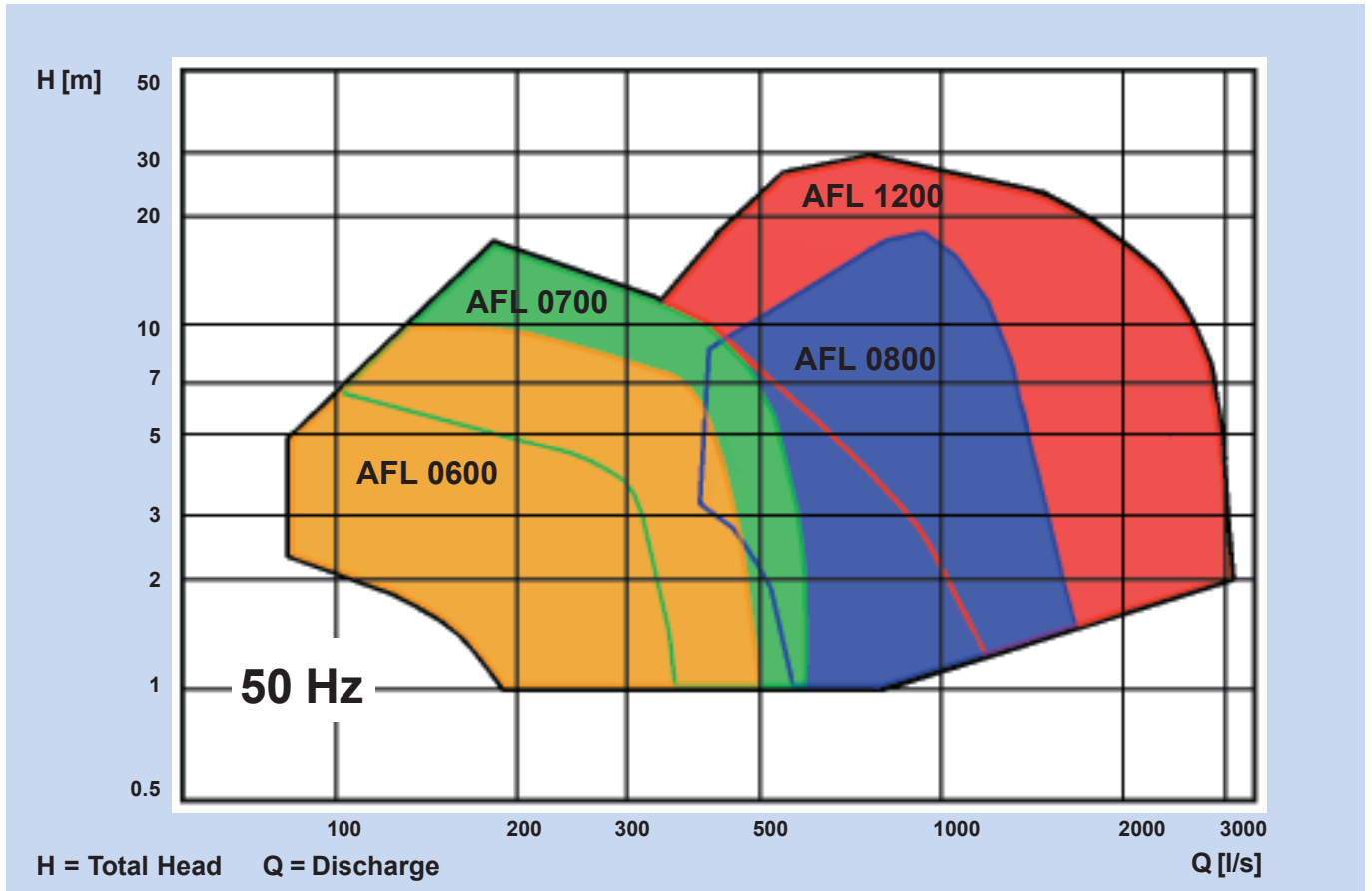

Identification Code

AFL 0801 M 900/6-55.EX

Series _____
 Wastewater-Faecal Matter-Lifter _____
 Pump Hydraulics _____
 Nominal Size 800 mm _____
 Final Digit 1 or 2 = Impeller Type _____
 Modular Motor _____
 Motor Power P_2 [kW] x 10 _____
 Number of Poles _____
 Motor Size _____
 Explosion Proof Version (European) _____

Motor Sizes

For the series AFL 0600 to 1200 medium cooled submersible motors with a range of speeds within the output range of 15 to over 650 kW are used. They are available for all common voltages from 380 to 1000 V in 50 Hz and 60 Hz versions.

Technical data sheets with precise specifications and material information as well as characteristic curves to ISO 2548/C or ISO 3555/B and documentation on motor operation and starting characteristics are available for each pump type.

Materials

Motorhousing _____ Cast Iron GG-25 (ASTM A48 Class 35)
 Rotor Shaft _____ Stainless Steel 1.4021 (ASTM A276 Type 416)
 Inlet _____ Cast Iron GG-25 (ASTM A48 Class 35)
 Guide Ring _____ Cast Iron GG-25 (ASTM A48 Class 35)
 Impeller _____ Cast Iron GG-25 (ASTM A48 Class 35)
 Fasteners in contact with medium _____ Stainless Steel 1.4401 (ASTM A276 Type 316)
 Coupling Ring _____ 1.0446 (GS 45)

Options:

Rotor Shaft _____ Stainless Steel 1.4462 (ASTM ~A182 Type 329)
 Impeller _____ wear resistant Stainless Steel 1.4460 (ASTM A351 Grade CD-4M CU)
 Coupling Ring _____ Stainless Steel 1.4408 (ASTM A351 Grade CF-8M)

AFL 0600 to 1200

ABS Mixed Flow Pump with Motor and Hydraulic Section designed on the modular principle

Pressure tight motor IP 68. Stator insulation Class F with thermal sensors. Rotor and shaft dynamically balanced

Lubricated-for-life ball and roller bearings support the shaft at bottom and top each with temperature monitors

Hydraulics with diffuser and adjustable wear gap at the suction side. Material Cast iron GG-25 (ASTM A48 Class 35)

All pumps are routinely tested during production to achieve the performance standard of ISO 2548/C. Performance tests to ISO 3555/B are also available

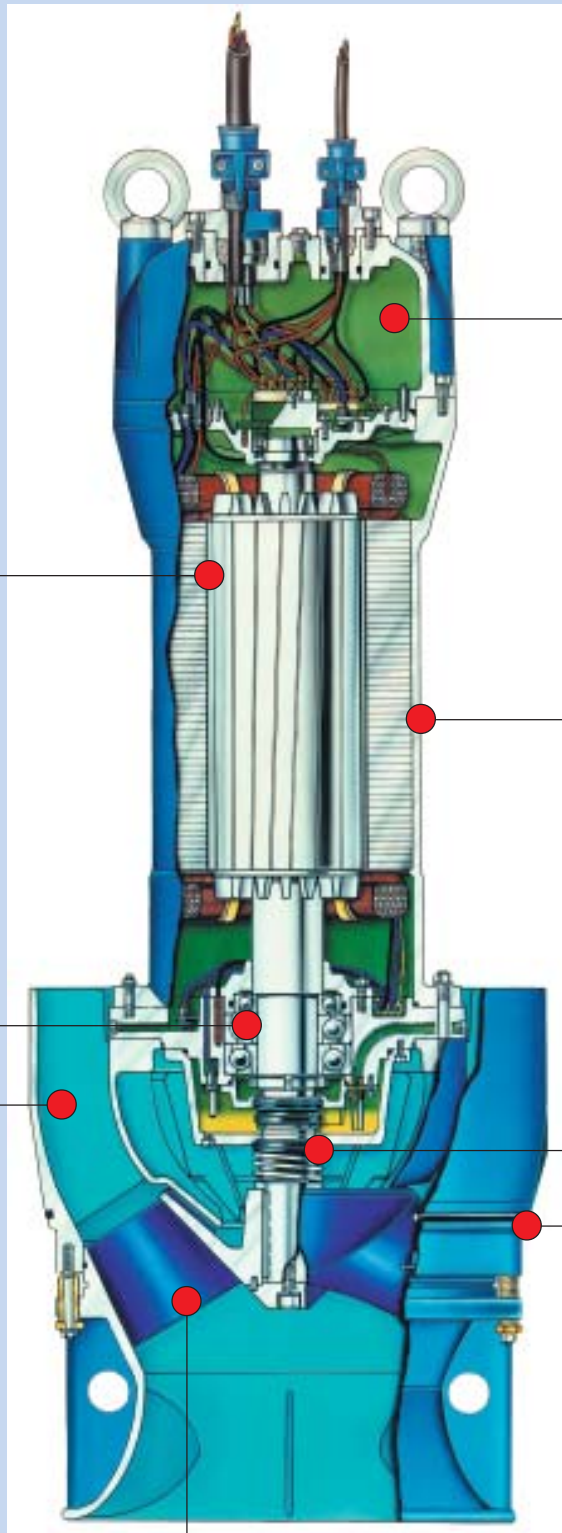

Pressure tight connection chamber IP 68. Cable entries with strain relief anti-kink protection and double sealing

Motor cooling optimised by directing the medium itself over the motor

High quality mechanical seal with solid silicon carbide rings for reliable shaft sealing

Automatic coupling mechanism ensures concentric, rotation proof and leak proof mounting

Mixed flow impeller material Cast iron GG-25 (ASTM A48 Class 35) also available in 1.4460 (ASTM A351 Grade CD-4M CU)

All motors are also available with explosion proof certification according to European standards or US FM standards

For optimum security and protection ABS offers a system of monitoring devices. By means of the permanent monitoring, faults and the effect of wear shows up in plenty of time. As a result major damage of the high quality submersible motor can be avoided by inspection or maintenance at the correct time.

Bearing Monitoring

Thermal sensors at the upper and lower bearings can be used to automatically switch off the motor if critical temperatures are reached.

Motor Monitoring

Thermal sensors in each phase of the stator can be used to switch off the motor before the allowable temperature limit is reached. Excessive temperatures can result from overloading, excessive medium temperatures or other factors.

Seal Monitoring

Sensor probes operate in conjunction with the electronic seal monitoring system to detect the ingress of moisture into the pressure tight encapsulated motor and connection chamber as well as into the oil chamber via the shaft seal. Independent of operating status, the ABS DI system warns of moisture ingress and correctly indicates the need for attention.

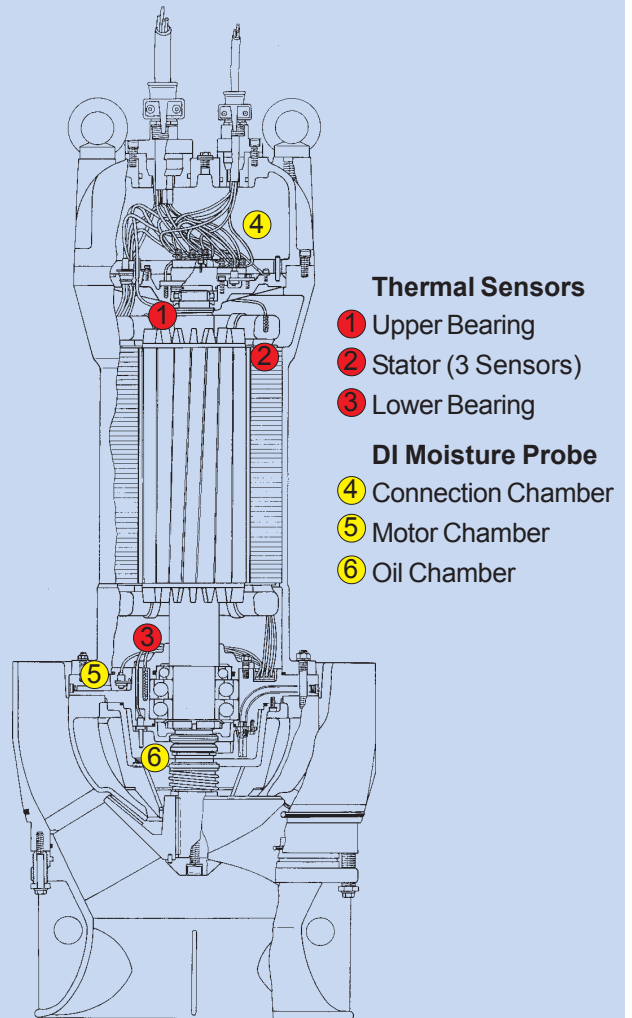

Motor Control Unit MCU-33

As an optional extra ABS can supply the required monitoring electronics for installation into the control panel.



■ in Concrete Sump

...with free outflow
over a weir

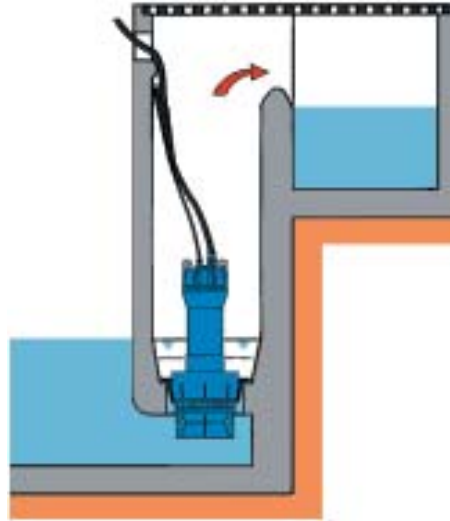

■ in a Steel Pipe

...with free outflow

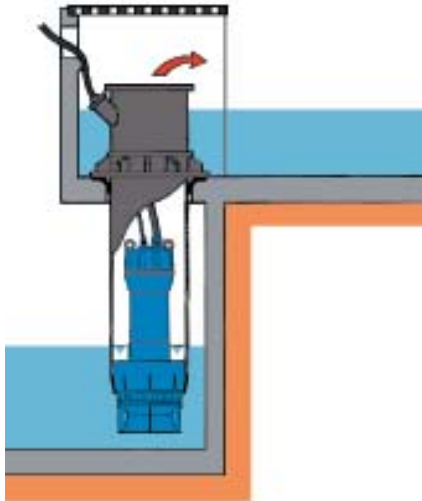

...with pressurized outflow
and non-return valve

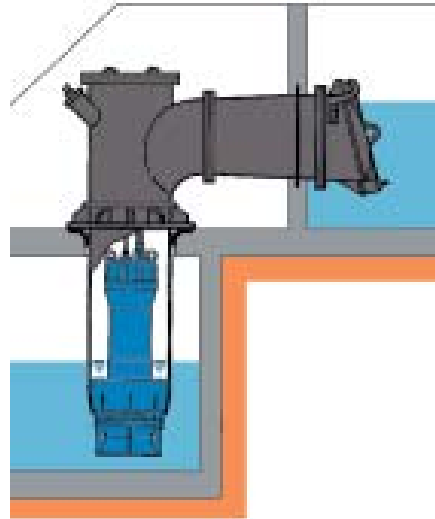

...with discharge elbow,
non-return valve, shut off valve and
discharge main

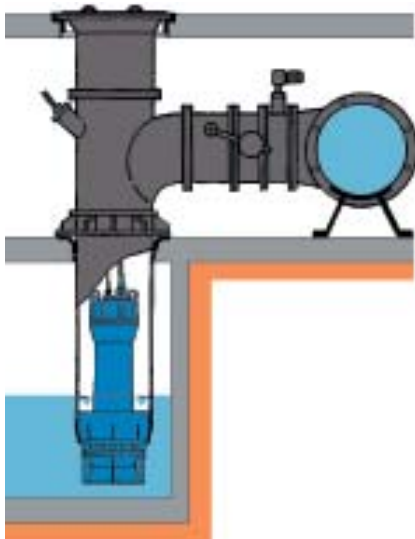

...with discharge elbow, and
siphon pipe with venting

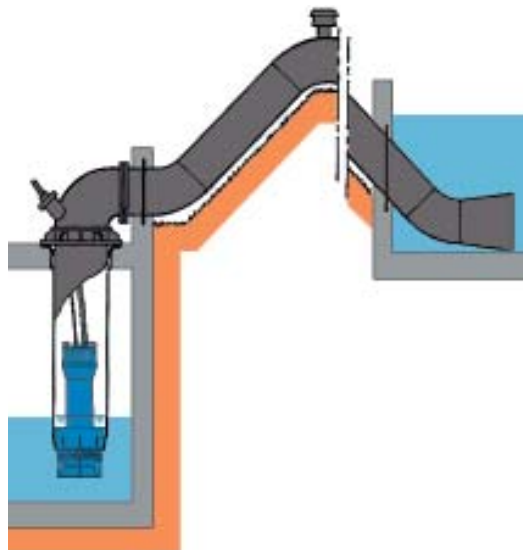

AFL 0600 to 1200

Dimensions

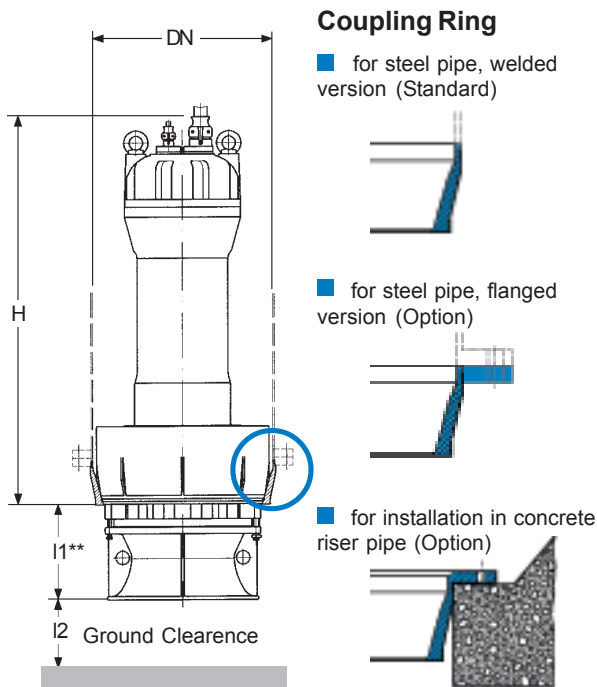

Technical Data

Type	Power Range	Number of Poles
AFL 0600	18.5 - 30 kW	6 - pole
	15 - 22 kW	8 - pole
AFL 0700	37 - 90 kW	6 - pole
	15 - 22 kW	8 - pole
AFL 0800	75 - 200 kW	6 - pole
	45 - 160 kW	8 - pole
	22 - 132 kW	10 - pole
AFL 1200	200 - 350 kW	10 - pole
	160 - 300 kW	12 - pole
	200 - 650 kW	4 - pole*

* with integral planetary gearbox. Thanks to the wide variety of gearbox ratios a precise matching of the optimum efficiency to the required duty point can be reached.

Type AFL DN	Motor	Weight kg	H mm	I1 mm	I2 mm
600	M 185/6-41	415	970	320	250
	M 220/6-42	435	1080	320	250
	M 300/6-43	455	1080	320	250
700	M 150/8-41	410	970	320	250
	M 185/8-42	440	1080	320	250
	M 220/8-43	450	1080	320	250
	M 370/6-51	820	1335	315	300
800	M 450/6-52	870	1335	315	300
	M 550/6-53	970	1485	315	300
	M 750/6-54	1030	1485	315	300
	M 900/6-55	1110	1575	315	300
	M 150/8-41	525	1025	315	300
	M 185/8-42	555	1135	315	300
	M 220/8-43	565	1135	315	300
	M 750/6-54	1300	1500	425	350
	M 900/6-55	1380	1600	425	350
	M 1100/6-61	1540	2320	425	350
1200	M 1320/6-62	1700	2460	425	350
	M 1600/6-71	1800	2480	425	350
	M 2000/6-72	1910	2480	425	350
	M 450/8-53	1250	1500	425	350
	M 550/8-54	1330	1500	425	350
	M 750/8-55	1380	1600	425	350
	M 900/8-61	1520	2320	425	350
	M 1100/8-62	1640	2460	425	350
	M 1320/8-63	1700	2460	425	350
	M 1600/8-71	1890	2480	425	350

Type AFL DN	Motor	Weight kg	H mm	I1** mm	I2 mm
800	M 220/10-51	1000	1350	425	350
	M 300/10-52	1050	1350	425	350
	M 370/10-53	1180	1500	425	350
	M 450/10-54	1240	1500	425	350
	M 550/10-55	1380	1600	425	350
	M 750/10-61	1530	2320	425	350
	M 900/10-62	1660	2460	425	350
	M 1100/10-71	1700	2330	425	350
1200 G**	M 1320/10-72	1910	2480	425	350
	M 2000/4-71 G	3670	2395	585	600
	M 2500/4-72 G	3720	2545	585	600
	M 3000/4-81 G	3870	2575	585	600
	M 3500/4-82 G	4070	2675	585	600
	M 4000/4-83 G	4270	2815	585	600
	M 4500/4-91 G	4980	3045	585	600
	M 5000/4-92 G	5100	3045	585	600
1200**	M 5500/4-93 G	5270	3165	585	600
	M 6000/4-94 G	5500	3275	585	600
	M 6500/4-95 G	6070	3425	585	600
	M 2000/10-82	3700	2465	585	600
	M 2500/10-91	4420	2525	585	600
	M 3000/10-92	4800	2645	585	600
	M 3500/10-93	5500	2905	585	600
	M 1600/12-91	4170	2405	585	600
1200	M 2000/12-92	4470	2525	585	600
	M 2500/12-93	4930	2755	585	600
	M 3000/12-94	5640	2905	585	600

Data applies to 50 Hz versions.

Exact dimensions for the design of a pump station can be obtained from the individual dimension sheet.

** I1 = 700 for AFL 1203

ABS offers the Complete Programme

AFP

Submersible pumps from 1.3 to 850 kW. Pressure-tight encapsulated fully flood-proof motors. Hydraulics with ContraBlock®-System or closed, single or multivane impellers for handling clear water, polluted water, sewage containing solids, faecal slurry and sludge.

Suitable for both wet well and dry well installation.



VUP

Submersible propeller pumps for pumping large volumes up to 7,000 l/s at heads up to 12 m.

Areas of application: Reclaimed land dewatering, flood protection, irrigation, aqua-culture, cooling and process water handling as well as recirculation in sewage treatment plants.



ECOMIX®

RW 300 - 900

Submersible mixers with motors from 1.5 to 22 kW for mixing, blending, dissolving and suspension of solids in municipal and industrial treatment plants.



HYPOMIX®

Submersible bottom mounted mixers for stirring activated sludge, particularly in square and round tanks.

The hyperboloid shape contributes to a very high efficiency and low energy consumption.



FB

Clogless ISO 5199 pumps, incorporating in the Modular System.

High casing wall thickness and duty matched impellers, Vortex or two-channel, give durability and long service life.



System Frings™

Self-aspirating submersible aerators for wastewater and water treatment in municipal and industrial plants.

Main areas of application are mixing and equalisation tanks, activated sludge tanks, SBR-reactors and sludge storage tanks.

Oxygen transfer up to 70 kgO₂/h, motor output, max 75 kW.

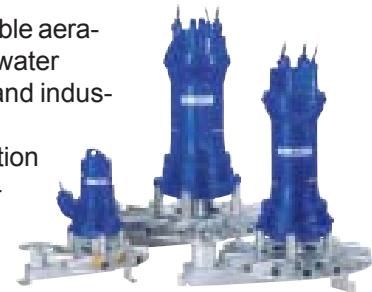

ABS reserves the right to alter specifications due to technical developments.

ABS
COST-EFFECTIVE PUMPING

Austria
Tel. +43 2236 642 61
Fax +43 2236 642 66

Belgium
Tel. +32 2 725 79 00
Fax +32 2 725 71 19

Brazil
Tel. +55 41 227 8100
Fax +55 41 348 1879

Canada
Tel. +1 905 670 4677
Fax +1 905 670 3709

China:
Tel. +86 21 5234 0472
Fax +86 21 5234 1179

Denmark
Tel. +45 48 17 11 10
Fax +45 48 17 19 11

Estonia
Tel. +372 656 3398
Fax +372 656 3385

Finland
Tel. +358 9 506 88 90
Fax +358 9 55 80 53

France
Tel. +33 1 49 35 24 50
Fax +33 1 48 54 42 82

Germany
Tel. +49 2246 13 0
Fax +49 2246 13 200

Great Britain
Tel. +44 1293 744 800
Fax +44 1293 543 392

Greece
Tel. +30 210 95 325 01/02/03
Fax +30 210 95 325 04

Hungary
Tel. +36 1 231 6070
Fax +36 1 231 6080

Ireland
Tel. +353 1 460 8888
Fax +353 1 460 8889

Italy
Tel. +39 051 89 00 911
Fax +39 051 86 18 48

Netherlands
Tel. +31 30 242 56 78
Fax +31 30 241 03 46

Norway
Tel. +47 67 554 700
Fax +47 67 554 750

Poland
Tel. +48 22 633 82 87
Fax +48 22 633 86 44

Portugal:
Tel. +351 21 495 01 57
Fax +351 21 495 53 64

Singapore
Tel. +65 6 4633 933
Fax +65 6 4622 122

South Africa
Tel. +27 11 397 1612
Fax +27 11 397 1795

Spain
Tel. +34 91 670 28 51
Fax +34 91 666 58 68

Sweden
Tel. +46 31 706 16 00
Fax +46 31 27 29 20

Switzerland
Tel. +41 71 694 6555
Fax +41 71 694 6556

Turkey
Tel. +90 216 455 2256
Fax +90 216 455 2265

USA
Tel. +1 203 238 2700
Fax +1 203 238 0738

All other countries
ABS Pumps International
Head Office, Sweden
Tel. +46 31 83 63 00
Fax +46 31 16 79 14

Agents and distributors
ABS has sales and service representation in more than 100 countries the world over.

www.abspumps.com

ABS is a company in the Cardo Group