

Call 800-810-1053 for HELP

6" Engine Driven Trash Pumps

Pump Dimensional and Specification Data

Model	Curve	Driver	Tank Size	Run Time	Max Solids Dia.	BASE	Ship Wt.	Engine Type
5581-96	A	Honda GX670 V-Twin	12 Gal.	6 Hrs.	3"	Trailer	1000 lbs.	2Cyl. Air Cooled
5582-96	A	Honda GX670 V-Twin	12 Gal.	6 Hrs.	3"	Skid	725 lbs.	2Cyl. Air Cooled
5583-D6	A	Daihatsu Vanguard 3/LC	16 Gal.	9 Hrs.	3"	Trailer	1125 lbs.	3Cyl. Liquid Cooled
5584-D6	A	Daihatsu Vanguard 3/LC	16 Gal.	9 Hrs.	3"	Skid	850 lbs.	3Cyl. Liquid Cooled

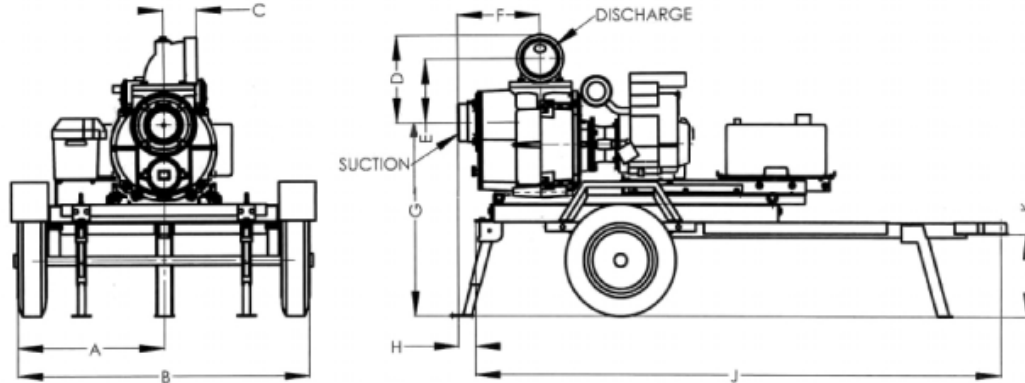

Model	A	B	C	D	E	F	G	H	J	K	Suction	Discharge
5581-96	26	52	5.9	15.2	11.2	14.7	33.2	3	92.3	14.4	6" NPT-M	6" NPT-F
5582-96	19	38	5.9	15.2	11.2	14.7	N/A	N/A	55	N/A	6" NPT-M	6" NPT-F
5583-D6	26	52	5.9	15.2	11.2	14.7	33.2	3	92.3	14.4	6" NPT-M	6" NPT-F
5584-D6	19	38	5.9	15.2	11.2	14.7	N/A	N/A	55	N/A	6" NPT-M	6" NPT-F

Dimensions are in inches and have a tolerance of $\pm 1/8"$

Standard Features

- Cast Aluminum w/Cast Iron and Stainless Steel Parts for Long Lasting Durability
- Silicon Carbide/Viton Mechanical Seal and Buna O-Rings and Fapper/Check Valve
- Built-in Flapper Check Valve for Fast Priming to 20 ft.
- 3" Solids Handling Capability
- Delivers up to 1000 GPM
- Digital Tachometer/hourmeter Installed
- Low Oil Alert
- Available in Trailer Mounted or Skid Mounted
- D.O.T. Approved Trailer – See your state and local codes for registration
- Easy Cleanout and Service Features with the unique AMT Patent Pending Slide Mechanism
- Includes Tool Box with Open End and Hex Wrench Sets for Servicing Pump
- Maximum Temperature 180° F
- 12 VDC Electric Start and Battery Included
- Steel Suction Strainer and Nipple Included



See price book page 5

The Gorman-Rupp Company reserves the right to discontinue any model or change specifications at any time without incurring any obligation.

CP17-18 / 1006

18

Call 800-810-1053 for HELP