



INDUSTRIAL DUTY

6" Engine Driven Trash Pumps

NEW DIESEL MODEL AVAILABLE

- *Cast Aluminum Casing and Adapter*
- *Cast Iron Seal Plate, Volute & Manifold*
- *Stainless Steel Impeller*
- *Silicon Carbide Mechanical Seal and Buna O-Rings & Flapper/Check Valve*
- *6" NPT Port Size*
- *Self Priming to 20 Ft.*
- *Honda GX670 V-Twin Gas Engine or Daihatsu Vanguard 3/LC Diesel*
- *Available in Trailer Mounted or Skid Mounted*
- *Solids Handling to 3" Diameter*
- *Unique Slide Mechanism Permits Complete Service of Pump Without Removing Hoses or Removing Pump Components From Trailer, PATENT PENDING*
- *Includes Tool Box and Tools for Servicing*
- *12 VDC Electric Start; Battery & Digital Tachometer/hourmeter Included*
- *D.O.T. Approved Trailer – See Your State and Local Codes For Registration*



6" Diesel Driven Trash Pump

The AMT 6" engine driven pump is designed for applications requiring high volume flow and solid/debris handling capabilities. Pump is constructed of heavy duty sand cast aluminum with cast iron and stainless steel internal parts for wear resistance and durability. Patent pending built-in slide mechanism features nylon and powder coated steel components that permit servicing, repairing and cleaning entire pump without removing hoses or pump components from trailer. Digital tachometer/hourmeter.

AMT Engine Driven Trash pumps are reliable, cost effective and low maintenance. Many are readily available "Off-the-Shelf" for fast 24 hour shipment. For use with non-flammable liquids which are compatible with pump component materials.

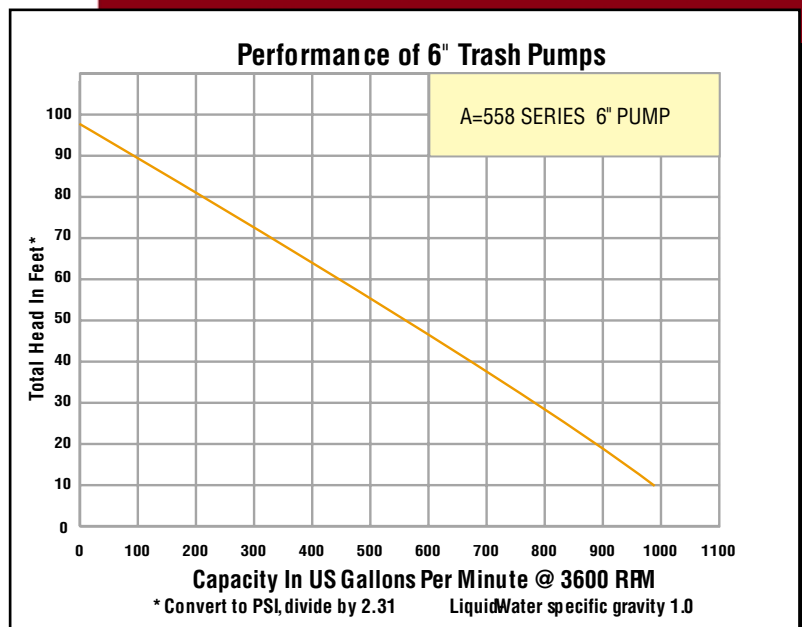

Call 800-810-1053 For Help

6" Engine Driven Trash Pumps

Call 800-810-1053 For Help

Pump Dimensional and Specification Data

Model	Curve	Driver	Tank Size	Run Time	Max Solids Dia.	BASE	Ship Wt.	Engine Type
5581-96	A	Honda GX670 V-Twin	12 Gal.	6 Hrs.	3"	Trailer	1000 lbs.	2Cyl. Air Cooled
5582-96	A	Honda GX670 V-Twin	12 Gal.	6 Hrs.	3"	Skid	725 lbs.	2Cyl. Air Cooled
5583-D6	A	Daihatsu Vanguard 3/LC	16 Gal.	9 Hrs.	3"	Trailer	1125 lbs.	3Cyl. Liquid Cooled
5584-D6	A	Daihatsu Vanguard 3/LC	16 Gal.	9 Hrs.	3"	Skid	850 lbs.	3Cyl. Liquid Cooled

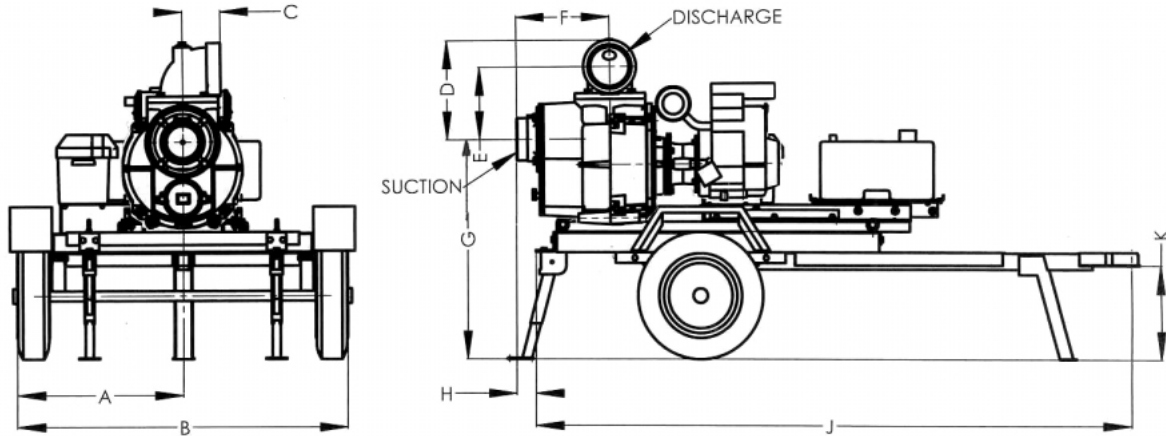

Model	A	B	C	D	E	F	G	H	J	K	Suction	Discharge
5581-96	26	52	5.9	15.2	11.2	14.7	33.2	3	92.3	14.4	6" NPT-M	6" NPT-F
5582-96	19	38	5.9	15.2	11.2	14.7	N/A	N/A	55	N/A	6" NPT-M	6" NPT-F
5583-D6	26	52	5.9	15.2	11.2	14.7	33.2	3	92.3	14.4	6" NPT-M	6" NPT-F
5584-D6	19	38	5.9	15.2	11.2	14.7	N/A	N/A	55	N/A	6" NPT-M	6" NPT-F

Dimensions are in inches and have a tolerance of $\pm 1/8"$

Standard Features

- Cast Aluminum w/Cast Iron and Stainless Steel Parts for Long Lasting Durability
- Silicon Carbide/Viton Mechanical Seal and Buna O-Rings and Fapper/Check Valve
- Built-in Flapper Check Valve for Fast Priming to 20 ft.
- 3" Solids Handling Capability
- Delivers up to 1000 GPM
- Digital Tachometer/hourmeter Installed
- Low Oil Alert
- Available in Trailer Mounted or Skid Mounted
- D.O.T. Approved Trailer – See your state and local codes for registration
- Easy Cleanout and Service Features with the unique AMT Patent Pending Slide Mechanism
- Includes Tool Box with Open End and Hex Wrench Sets for Servicing Pump
- Maximum Temperature 180° F
- 12 VDC Electric Start and Battery Included
- Steel Suction Strainer and Nipple Included